

MaineDOT Gateway Treatment Options

Background

Maine has seen an increase in both pedestrian and bicyclist fatalities in recent years. These crashes can be attributed to many factors: distracted driving, inattention, weather, roadway geometry and improper speed.

MaineDOT is offering a Village Program to partner with municipalities to help with potential roadway improvements that can aid in transforming the roadway to a condition that is more expected in a Village type area. Many Village areas offer little to no visual cues to drivers as they enter into the more built-up sections. MaineDOT's goal is to provide options to municipalities to help make their Village area feel less like the open road and more like the municipalities vision for the area. One way to enhance a village area is incorporate some type of speed control into the roadway template.

MaineDOT is developing a toolbox of lower cost options to help counter the impacts of speeding vehicles. The solutions shown below in this document can be used independently of one another or in conjunction with many or all of the proposed solutions.

Municipalities may not know what may or may not work within their community and may not want to spend a lot of money installing permanent devices. MaineDOT and their partners from the Bicycle Coalition of Maine have created a program for municipalities to demonstrate how each of the possible solutions could work using temporary devices. A municipality wanting more information on this subject can work with the Region Traffic engineer out of the region office or to the regional planner assigned to your area.

What is a village area? A village area is a densely built-up area along a state highway with a posted speed limit of 35 mph or less. In order to qualify for the Village Program, the built-up area would need to be at least a half mile in length and offer a mixture of residential and commercial activities. Usually, there is on-street parking located in the vicinity as well as pedestrian activities (although a sidewalk is not required to be considered a village). Areas posted 40 and 45 mph are also eligible for the village program, if the applicant can demonstrate that their Village proposal has a chance to bring the operating speed down to at least 35 mph. This can be done through testing in a demonstration project as shown above, or via another similar project that showed an appropriate operating speed reduction.

Proposed Solutions

Step Down Speed - One of the simplest solutions is to provide a step down in the posted speed limit entering into a village area. MaineDOT's speed zone guidelines were developed to set speed limit drops of 10 mph or less heading into a built-up area. In areas where there are larger speed differentials heading into a village area, MaineDOT will strive to create proper the proper stepdown speeds to facilitate a reduction in operating speed. The new stepdown speed zone should be created by shortening the higher speed limit and rather than out of the lower village speed limit. While this might not be the most successful strategy in slowing traffic down, it does give advanced warning to the driver and any bit of speed reduction is worthwhile however it is accomplished. (See Figure 1 below).

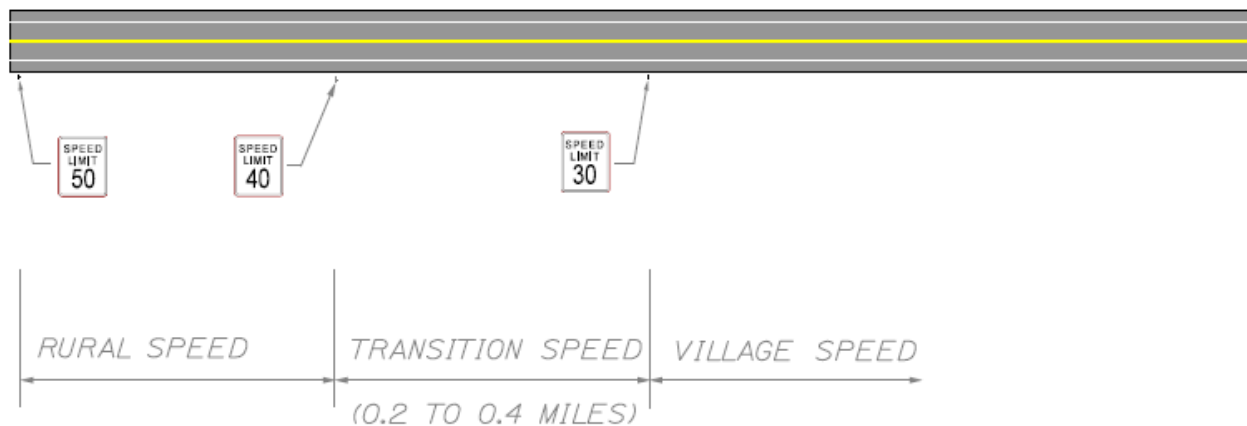

Fig.1 - Step Down Speed

Painted Markings - Painted stencil markings or preformed thermoplastic shields may be used on the roadway further call attention to the posted speed limit. These markings, mostly because of their size, further reinforce the posted speed to vehicular drivers. This is a fairly low-cost treatment but requires continuing maintenance.



Speed Limit Sign Enhancements (Dynamic Signs) - Sometimes even developing a new stepdown speed is not enough to create the operating speeds desired for a village area. The typical black on white speed limit sign may need some additional enhancements in order to achieve the desired conspicuity. There are several ways to bring attention to a step-down speed. Adding orange flags to the speed zone signs is a low-cost solution to help capture a driver's attention. Other low-cost solutions (< \$1,000) include over-sizing the speed limit sign or adding a red border around the sign. There are many dynamic solutions that would be considered medium cost (\$1,000 to \$10,000) available to municipalities trying to get motorists to slow down. The addition of flashing LED lights around the sign may increase conspicuity. These signs are often solar powered and need to be installed in areas of full sun. The addition of a solar powered LED flashing sign indicating "Village Area" can also help to further notify the driver they are entering into an area where slower speeds are appreciated. The most expensive of the medium cost treatments is the installation of a dynamic speed feedback sign. These signs provide operating speed feedback to the driver. MaineDOT guidelines require that the signs flash the vehicles speed if it is 1 mph to 10 mph over the posted speed limit and flash "Slow Down" for those traveling over 10 mph. (See Figure 2)

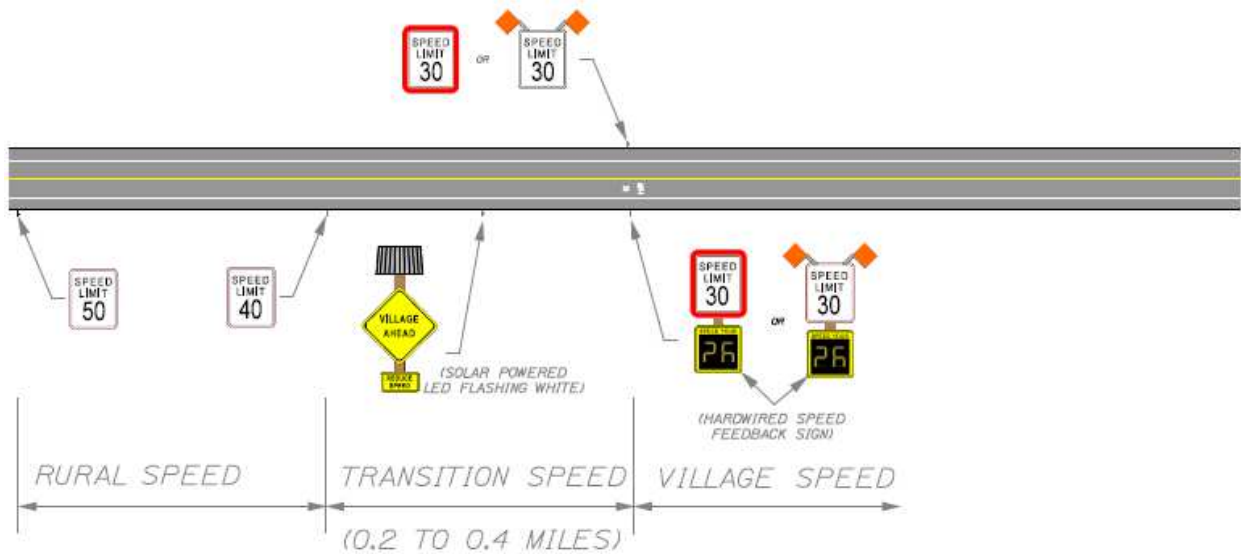

Fig.2 - Dynamic Signs

Center Islands and Optical Speed Bars - There are many instances where the roadway template outside a village area looks the same as the template within the village areas. There are no visual cues for the driver to want or need to slow down. Traffic calming measures may be used to help with the visual cues. Often traffic calming involves the construction of physical obstructions to help facilitate lower speeds. Construction of a center island whether painted, modified sloped granite curb like that used in a roundabout apron or typical type 5 sloped curb will provide the visual cue for a driver to slow down. These islands can be accompanied by tubular markers for added verticality. Chevron striping can be added in advance of the island and optical speed bars painted adjacent to the island to further add visual stimuli to driver. Center islands should be designed in such a manner that they are not used in super-elevated sections to avoid water being trapped in the center of the road. Painted partial chevrons may be added on the shoulder adjacent to the area where the center island has been constructed. These partial chevrons should extend a minimum of 1 foot into the travel lane and give the optical illusion that the road is narrowing down (See figure 3)

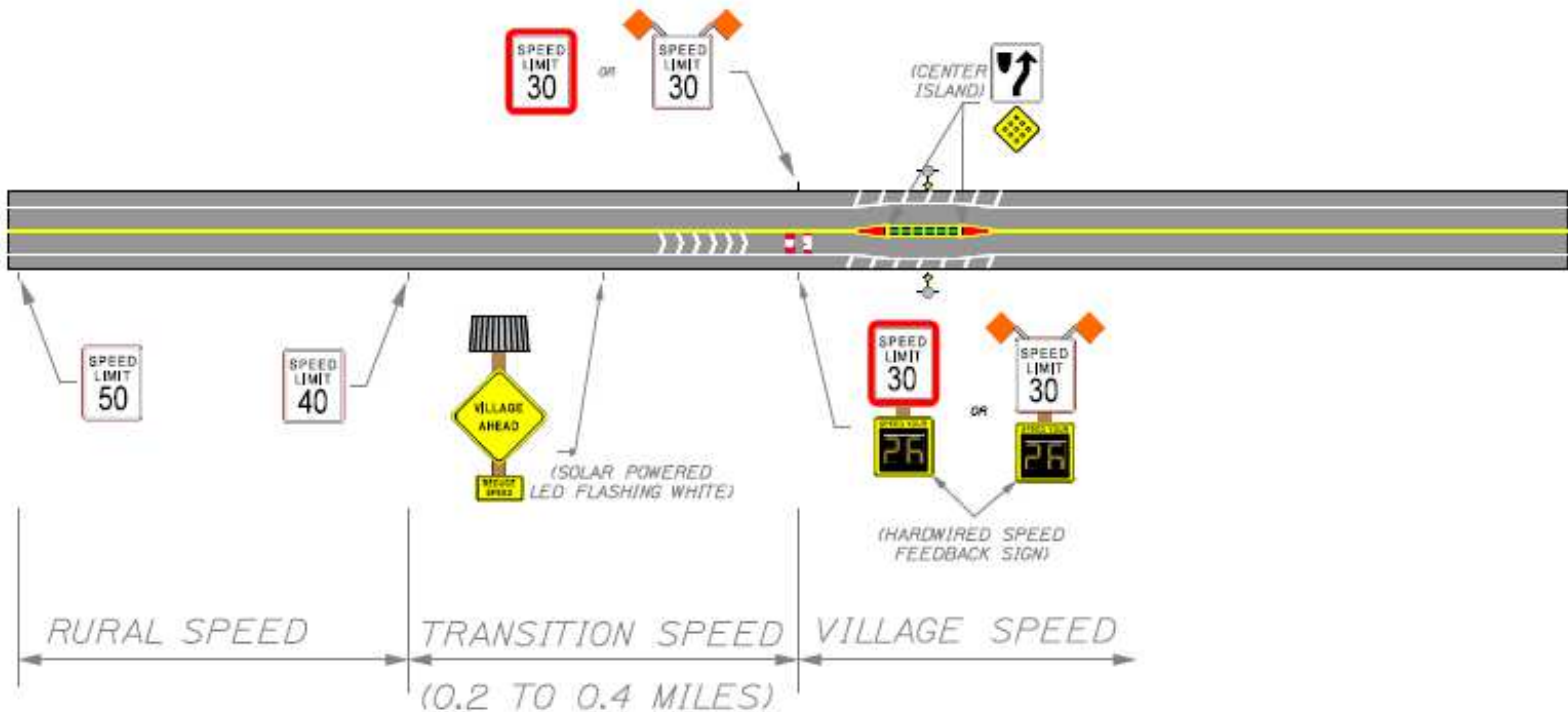

Fig.3 - Center Island

Bump-Outs - There are many locations where a center island may not be a potential solution due to Right of Way constraints or roadway widths confined by structural elements such as buildings and bridges. Bumpouts may be installed instead. A bump-out is a physical obstruction built on the shoulder of the roadway to make the roadway feel more constricted to the vehicular driver. Bump-outs may be painted, modified sloped granite curb like that used in a roundabout apron, typical type 5 sloped curb or with vertical curb depending on the individual site's characteristics. (See Figure 4) Both bump-outs and center islands may cause issues for plowing. Painted bump-outs or those with lower reveal curbing, such as the type installed for roundabout center islands, will make it easier for maintenance forces to plow over and around the bump-out or center island. Painted chevrons may be stenciled in advance of the bump-out as well as painted stencil speed markings could also help reinforce the suggested speed reduction. Bump-outs built with typical type 5 sloped granite curb or vertical curb may have additional vertical features such as tubular markers to help further indicate the need to slow down.

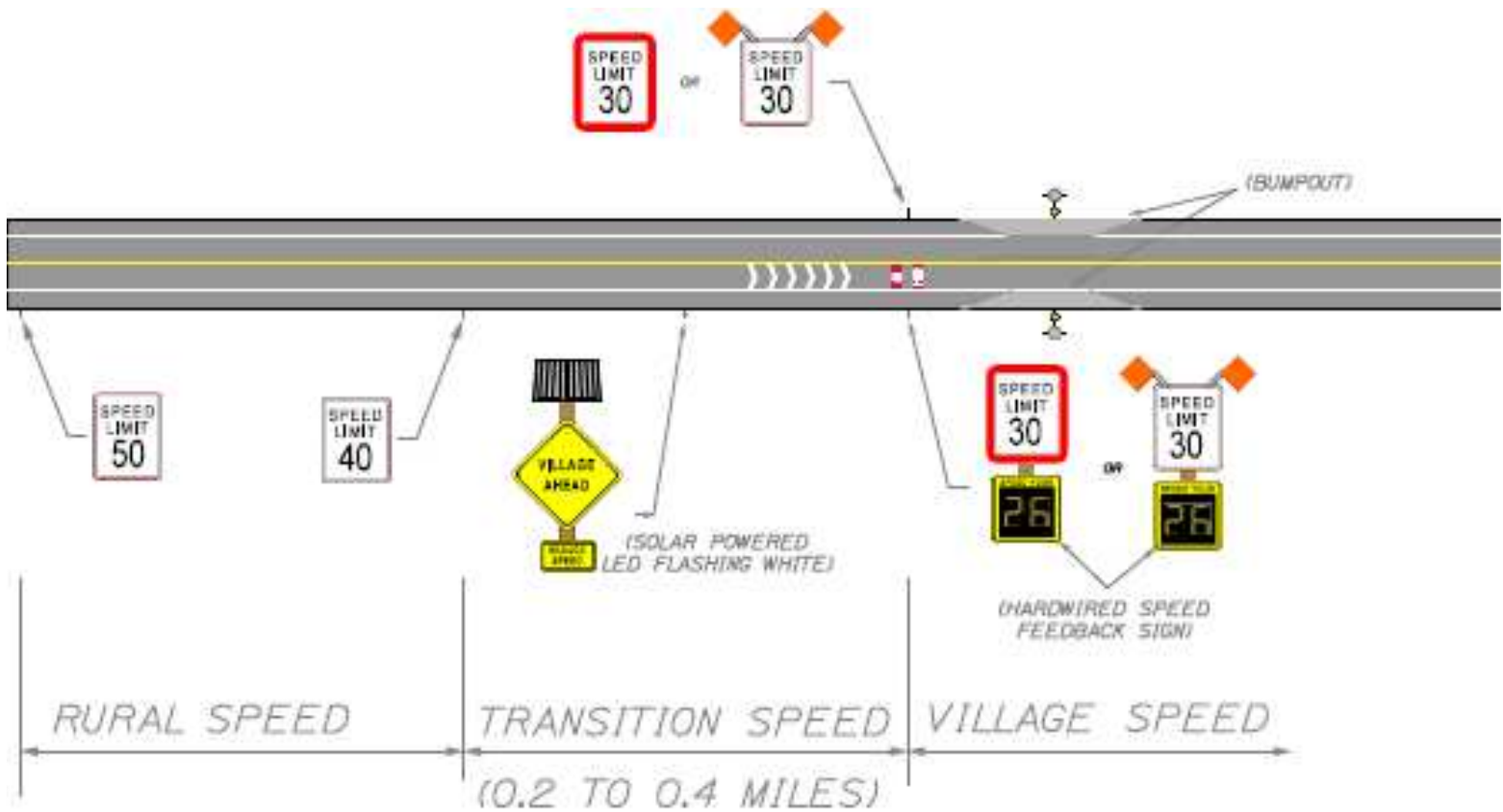

Fig.4 - Bump Outs

Speed Tables - The most aggressive in road treatment that can be used to slow traffic is the installation of speed tables. MaineDOT's typical speed table design is constructed as a 4 inch high table top a minimum of 10 feet in length (along center line) with 6 foot long ramps on either side. Speed tables typically stretch the full width of the travel way plus a majority of the shoulder. The tables typically taper down on the shoulder within a foot of the curb line to ensure that drainage is maintained and that surface water can reach existing catch basins. Speed tables need to have painted chevrons in advance of the table and painted chevrons on the ramps. All speed tables are required to have "Speed Table" signage with speed advisory signs installed in advance of each table. In order to be effective, more than one speed table may need to be installed on longer stretches of roadway. Speed tables currently cannot be used on arterial roadways without a special exception. Speed tables can also be used in conjunction with crosswalks to further help provide more conspicuity to pedestrians. The current traffic calming policy does not allow speed tables on certain classifications of roadway. Exceptions may be granted in select locations. (See Figure 5)

Designers should work closely with municipal fire and safety to ensure that they are on board with the installation of these features. Typically, they result in only a few seconds of delay. Speed tables can be either permanent or temporary. There are many entities that manufacture temporary molded rubber segmental tables that lag screw down into the roadway. These would be used when the need for traffic calming is seasonal such as in heavily touristed areas.

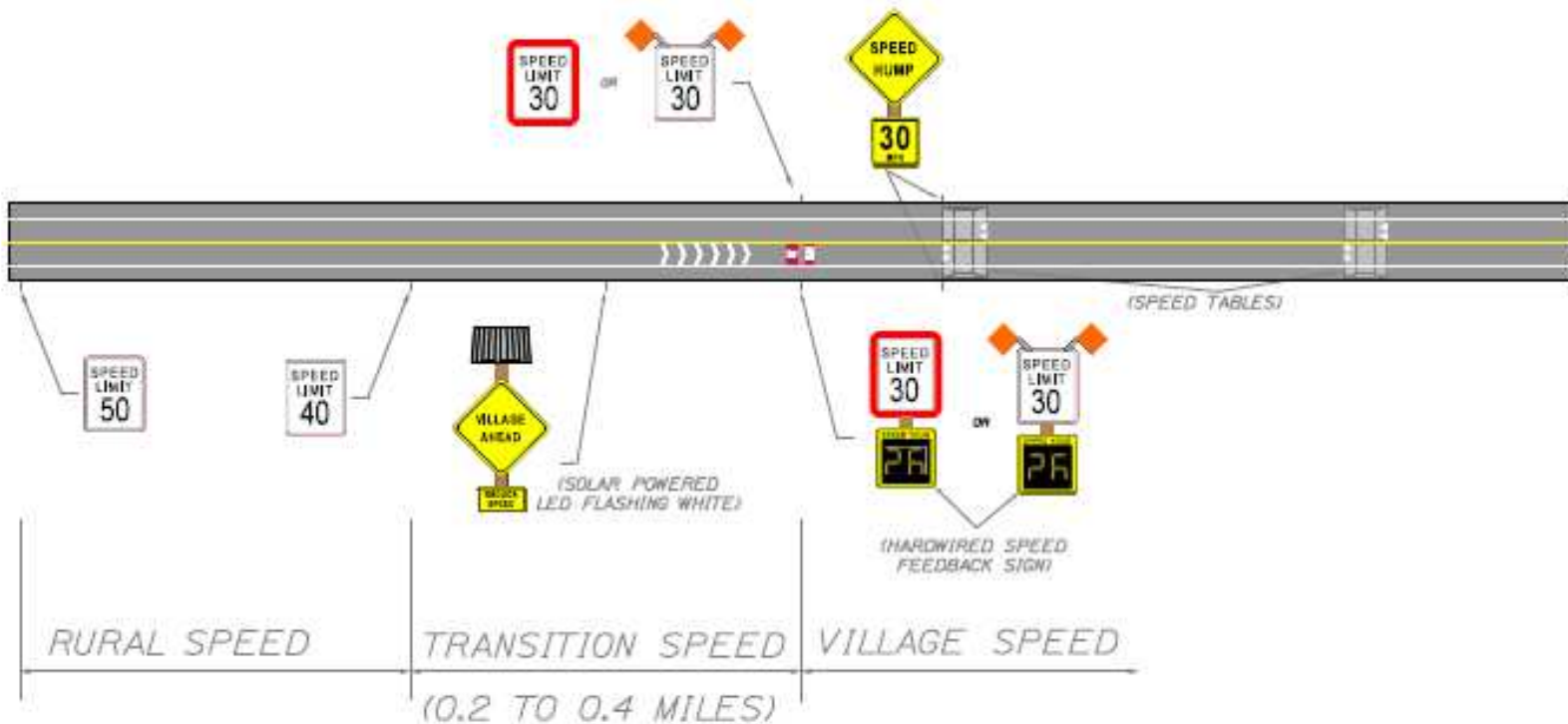

Fig.5 - Speed Tables

Bicycle symbols and Sharrows - Another indication of a village area is the inclusion of bicycles along with pedestrians. Simple stenciling a bike symbol and a sharrow can help make an area feel more village like. These symbols should be painted at least every quarter mile to remind vehicular drivers that bicyclists may be traveling in the lane. (See Figures 6 and 7.) **Refer to bike ped guidance**

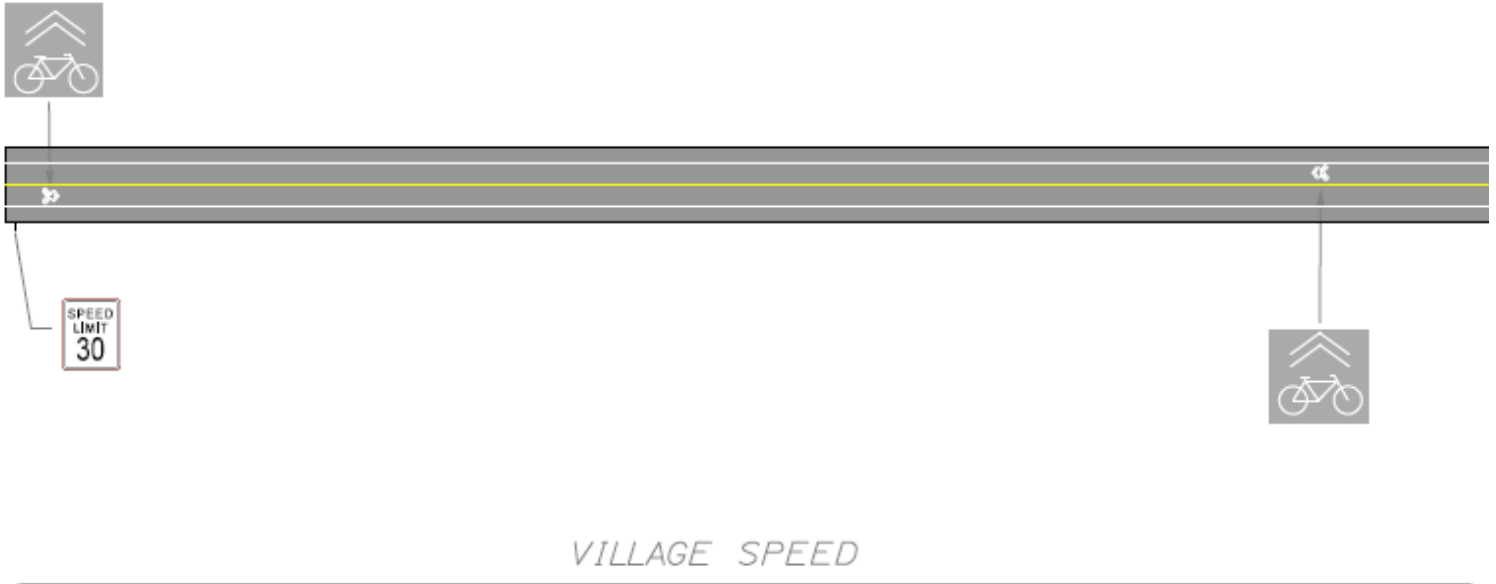

Figure 6 - Bicycle Symbol and Sharrows



Figure 7 – Assorted Bicycle signageto promote safety and reinforce village setting

Signage should be used in conjunction with the bicycle symbol and sharrows. These signs provide further guidance to the driver and provides verticality to the facility.

Sidewalk Construction, On-Street Parking, Crosswalks, Stenciling and other Lighted Devices – The addition of sidewalks can also help in reducing speed through a village area. A sidewalk provides visual cues to the driver that the setting has changed. Sidewalks tend to make the roadway feel narrower, tending to result in slower speeds. The addition of on-street parking further helps reduce the speed when vehicles are actually parked along the roadway. Sidewalks also provide the ability to add in crosswalks and assorted signing and stenciling associated with those facilities. The added marking and signs serve as further visual cues to the driver. Additional features such as Flashing pedestrian signs, Rectangular Rapid Flashing Beacons (RRFB's), Pedestrian Hybrid Beacons, In-Crosswalk lighting, Overhead lighting and bollard lighting, all would provide varying degrees of impact to the driver. (See Figures 8, 9, 10, 11,12 and 13)

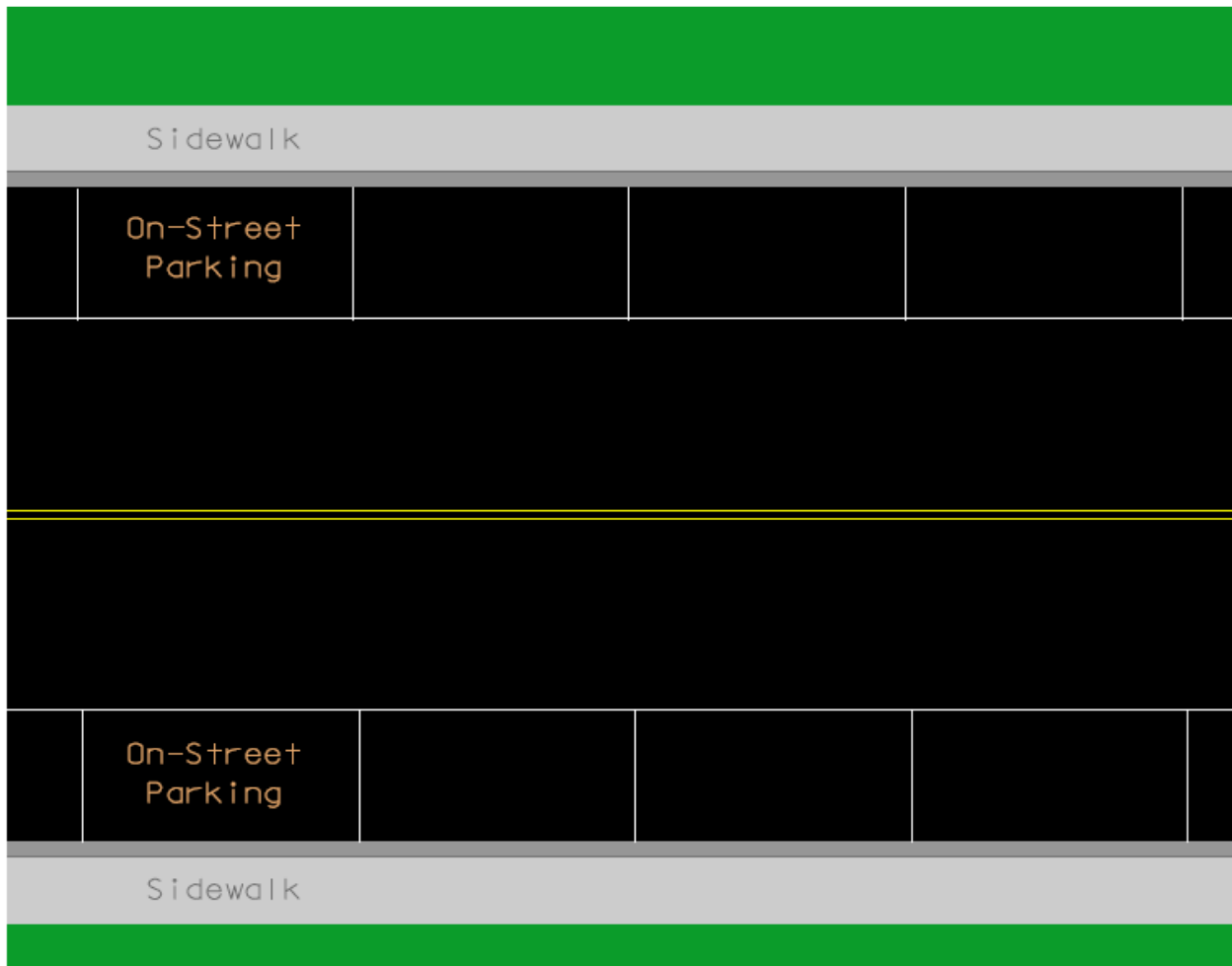

Figure 8 –Sidewalk and On-Street Parking

Side friction is an effective tool at slowing speeds along the roadway. Sidewalks and On-Street Parking are one way of slowing traffic through a village area. Adding crosswalks to the equation, along with crosswalk signage adds further evidence of a village setting. Visual cues are paramount to getting drivers to slow down in village areas.

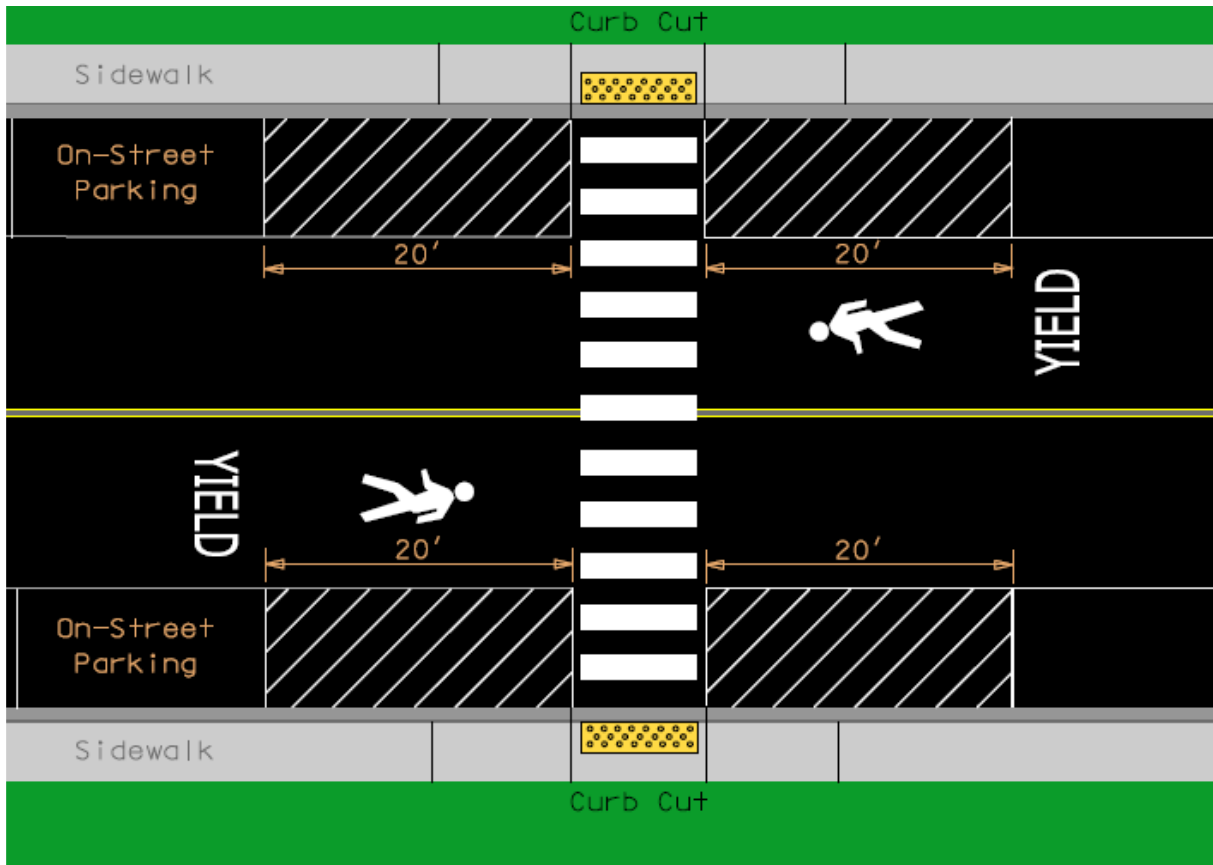

Figure 9 – Sidewalk with Crosswalk and Associated Stenciling

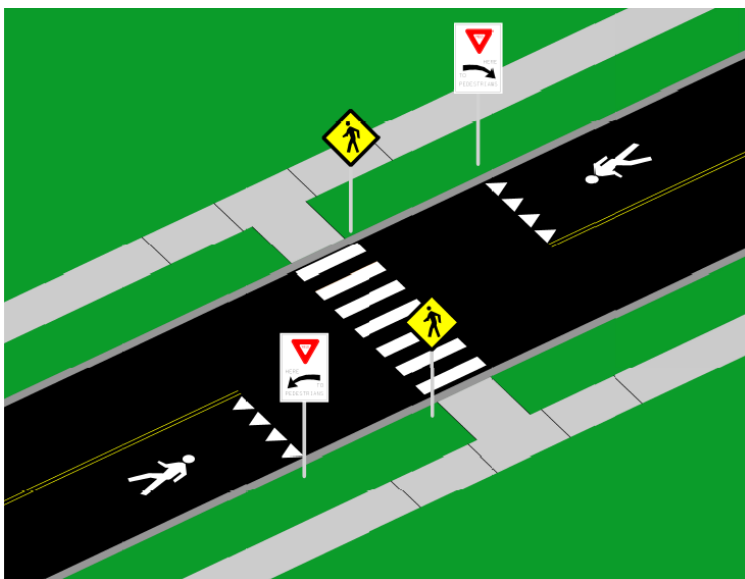

Figure 10 – Crosswalks with Yield Bars and Enhanced Signage

Adding yield bars and signage are another indication that a driver is in an area where they need to mitigate their speed to meet the usage in the surrounding area. Without visual cues, (stencil and signage) driver's cues are the two-dimensional crosswalk. The addition of the third dimension is imperative to get drivers to recognize the situation that they are encountering.



Figure 11 – Pedestrian Hybrid Beacon (PHB)

In-Road pedestrian signals are another tool that can be used to pass along information to the driver that a pedestrian may be crossing the roadway. These lights are pedestrian activated and flash while a pedestrian is crossing the roadway.

Pedestrian hybrid beacons (PHB) are another form of visual stimuli to alert the driver to alert them that they are in an area where they need to slow down. These lights are pedestrian activated. A PHB is an all-red indication that stops traffic to allow pedestrians to cross a roadway. They are mostly used in areas with more than two lanes, high traffic volumes and higher speeds. They should not be looked at as a solution in posted speeds higher than 45 mph.



Figure 12 – In-Road Pedestrian Lights



Rectangular Rapid Flashing Beacons (RRFB's) are push-button activated flashing crosswalk signs. They are extremely bright and can be seen for miles. They help with conveying the message that the area is built up and has pedestrian activity. RRFB's have been shown to have significant compliance rate (88 % +/-).

Figure 13 -Rectangular Rapid Flashing Beacons (RRFB)

Lighting is another indicator of a village location. Lighting can be either for vehicles or pedestrian level lighting. Care should be taken have lights placed to front light pedestrians as they enter a crosswalk. Bollard lighting can be a lower cost lighting solution for some municipalities.



Figure 14 – Pedestrian Lighting

Put something in for using tubular markers for traffic calming and to create bump-outs.

Appendix A

Optical Speed Bar Spacing

Total Length (40-45 MPH) 526 ft

Total Length (25-35 MPH) 344 ft

Spacing Between Optical Speed Bars (40-45 Mph)					
Bars	Spacing (Ft)	Bars	Spacing (Ft)	Bars	Spacing (Ft)
1-2	24	11-12	19	21-22	15
2-3	23	12-13	19	22-23	15
3-4	23	13-14	18	23-24	14
4-5	22	14-15	18	24-25	14
5-6	22	15-16	18	25-26	13
6-7	22	16-17	17	26-27	13
7-8	21	17-18	17	27-28	13
8-9	21	18-19	16	28-29	12
9-10	20	19-20	16	29-30	12
10-11	20	20-21	16	30-31	12

Table 1 – Optical speed bar spacing for Roadways Posted 40 to 45 MPH

Spacing Between Optical Speed Bars (25-35 Mph)					
Bars	Spacing (Ft)	Bars	Spacing (Ft)	Bars	Spacing (Ft)
1-2	18	11-12	13	21-22	10
2-3	16	12-13	13	22-23	10
3-4	16	13-14	13	23-24	10
4-5	16	14-15	12	24-25	10
5-6	15	15-16	12	25-26	9
6-7	15	16-17	12	26-27	9
7-8	15	17-18	11	27-28	9
8-9	14	18-19	11	28-29	9
9-10	14	19-20	11	29-30	8
10-11	14	20-21	11	30-31	8

Table 2 – Optical speed bar spacing for Roadways Posted 25 to 35 MPH

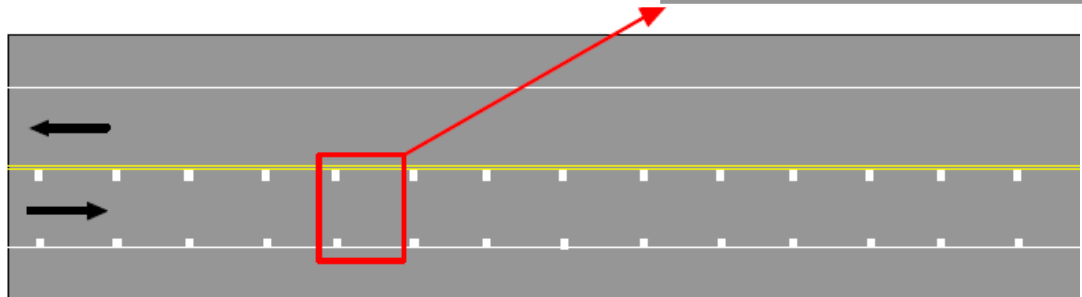
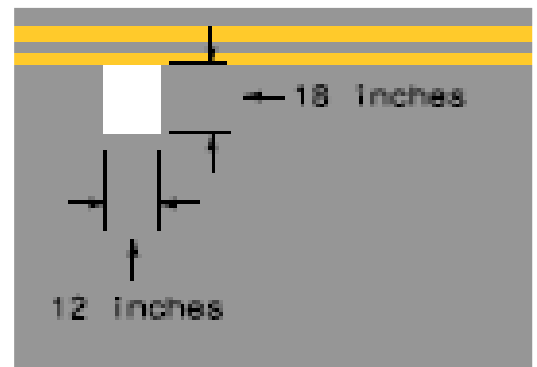

1Appendix A Figure 1 – Typical optical speed bar dimensions – spacing as shown in tables above.

Appendix B

Speed Table Design

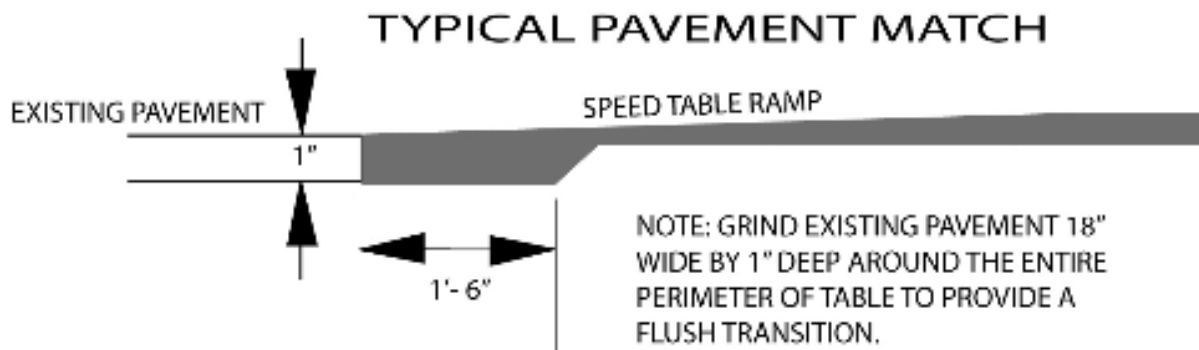
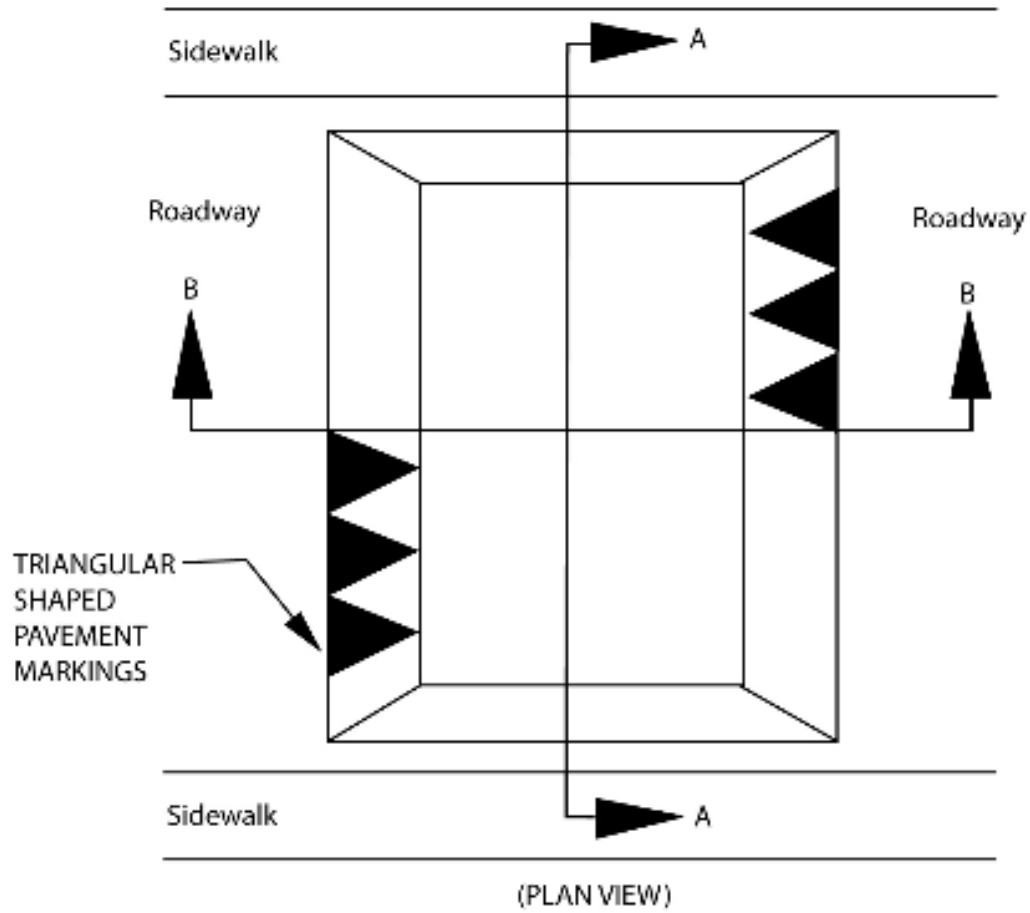

Appendix B (cont'd)

Speed Tables

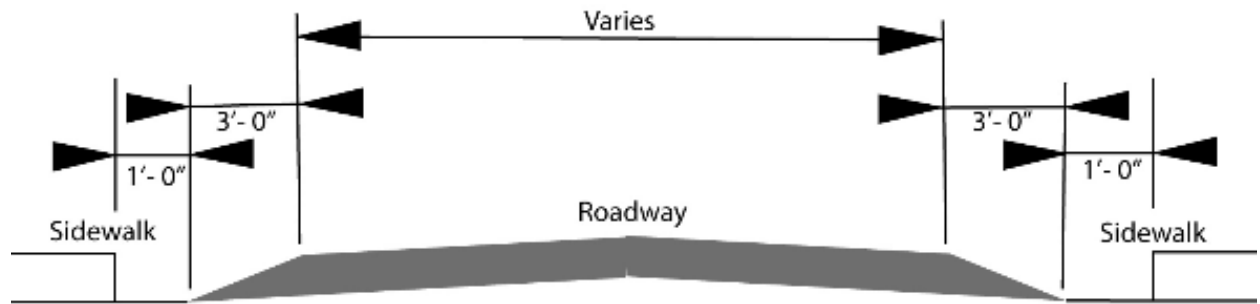

SECTION A-A

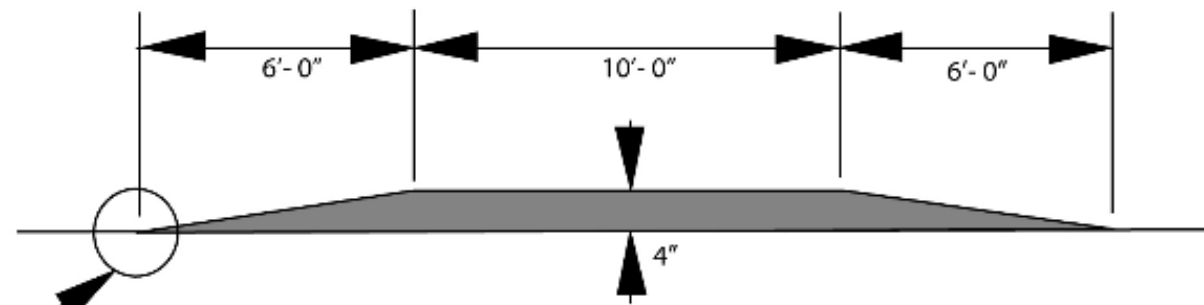

FLUSH PAVEMENT MATCH
(TYPICAL) See Detail

SECTION B-B

Appendix C

Painted Stencil Speed Limits

Painted Stencil Speed Limits

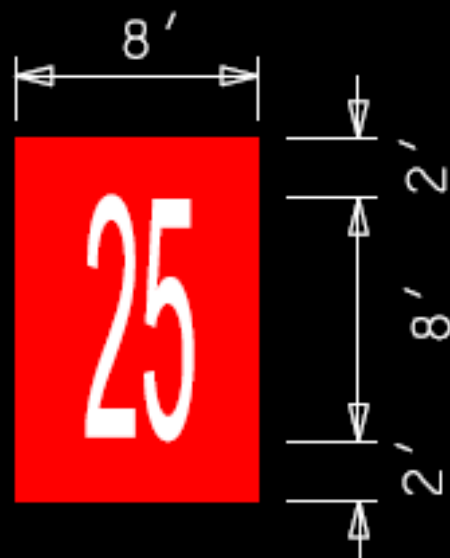
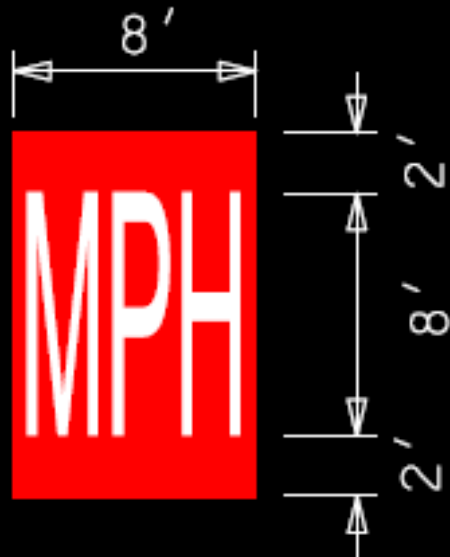

Note: Red background shall not be retro-reflective

Appendix D

Curbing Options for Center Islands and Bump-outs

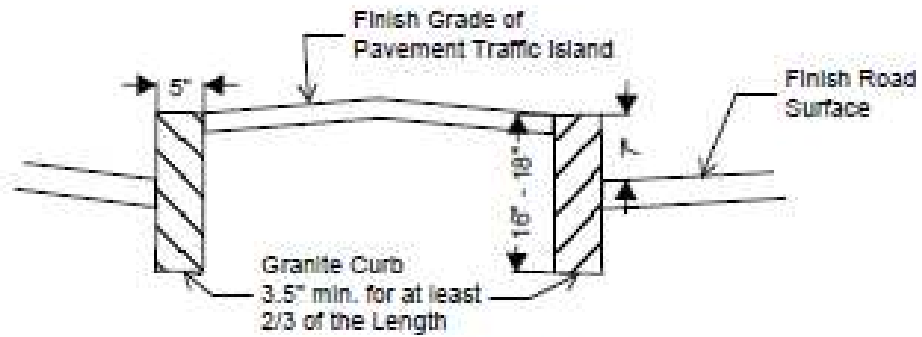

Traditional Vertical Curb - Type 1



Traditional Curb - Type 5

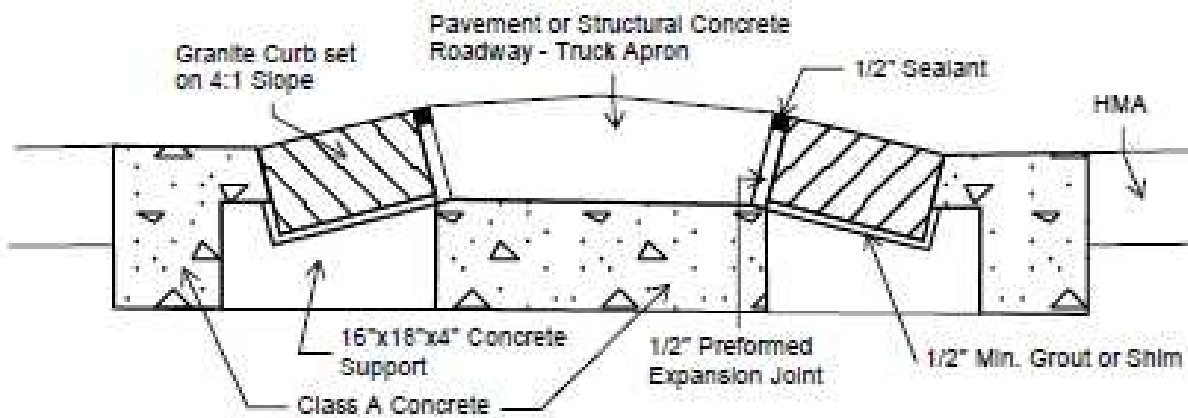

Low Reveal Curb - Type 5